

## STEPPER MOTOR DRIVING

By H. SAX

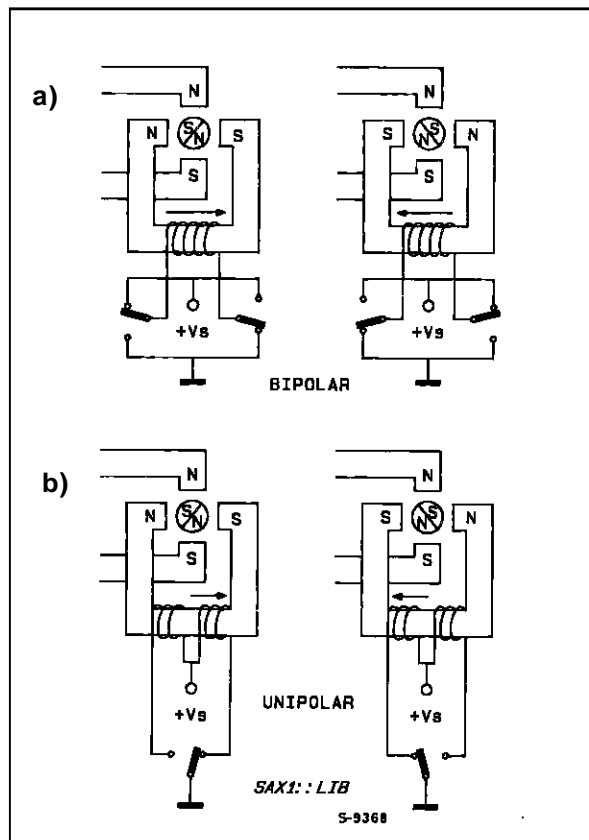
Dedicated integrated circuits have dramatically simplified stepper motor driving. To apply these ICs designers need little specific knowledge of motor driving techniques, but an under-standing of the basics will help in finding the best solution. This note explains the basics of stepper motor driving and describes the drive techniques used today.

From a circuit designer's point of view stepper motors can be divided into two basic types : unipolar and bipolar.

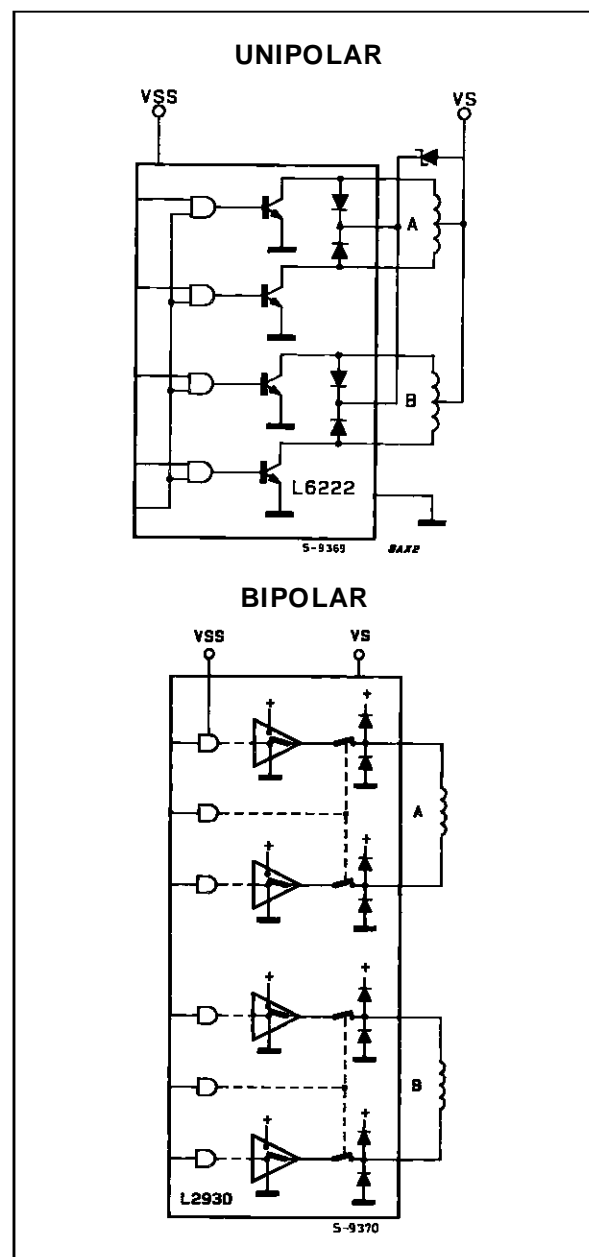
A stepper motor moves one step when the direction of current flow in the field coil(s) changes, reversing the magnetic field of the stator poles. The difference between unipolar and bipolar motors lies in the way that this reversal is achieved (figure 1) :

**Figure 1a** : BIPOLAR - with One Field Coil and Two Chargeover Switches That are Switched in the Opposite Direction.

**Figure 1b** : UNIPOLAR - with Two Separate Field Coils and are Chargeover Switch.



**Figure 2** : ICs for Unipolar and Bipolar Driving.



## APPLICATION NOTE

The advantage of the bipolar circuit is that there is only one winding, with a good bulk factor (low winding resistance). The main disadvantages are the two changeover switches because in this case more semiconductors are needed.

The unipolar circuit needs only one changeover switch. Its enormous disadvantage is, however, that a double bifilar winding is required. This means that at a specific bulk factor the wire is thinner and the resistance is much higher. We will discuss later the problems involved.

Unipolar motors are still popular today because the drive circuit appears to be simpler when implemented with discrete devices. However with the integrated circuits available today bipolar motors can be driven with no more components than the unipolar motors. Figure 2 compares integrated unipolar and bipolar devices.

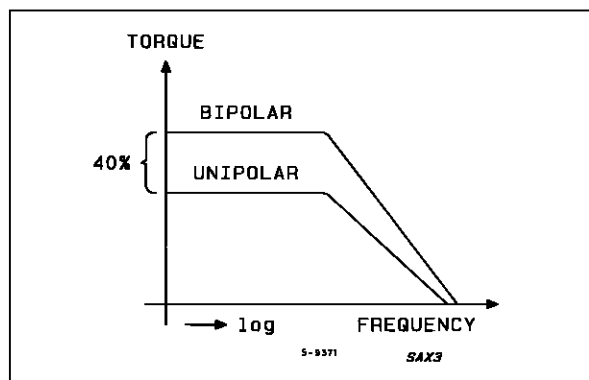
### BIPOLAR PRODUCES MORE TORQUE

The torque of the stepper motor is proportional to the magnetic field intensity of the stator windings. It may be increased only by adding more windings or by increasing the current.

A natural limit against any current increase is the danger of saturating the iron core. Though this is of minimal importance. Much more important is the maximum temperature rise of the motor, due to the power loss in the stator windings. This shows one advantage of the bipolar circuit, which, compared to unipolar systems, has only half of the copper resistance because of the double cross section of the wire. The winding current may be increased by the factor  $\sqrt{2}$  and this produces a direct proportional effect on the torque. At their power loss limit bipolar motors thus deliver about 40 % more torque (fig. 3) than unipolar motors built on the same frame.

If a higher torque is not required, one may either reduce the motor size or the power loss.

**Figure 3 :** Bipolar Motors Driver Deliver More Torque than Unipolars.

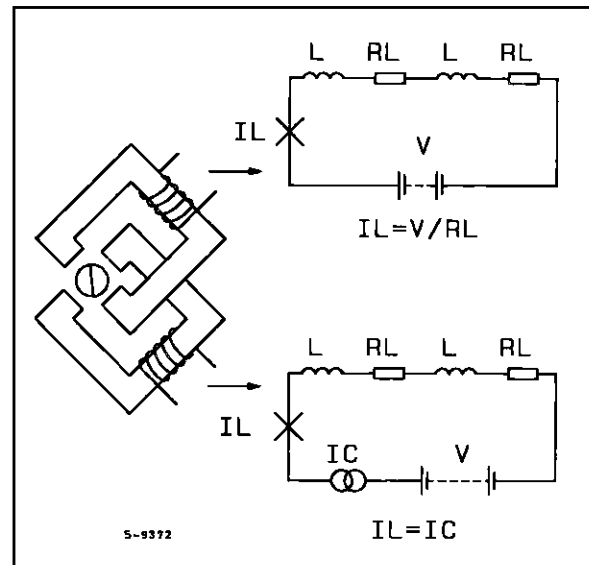


### CONSTANT CURRENT DRIVING

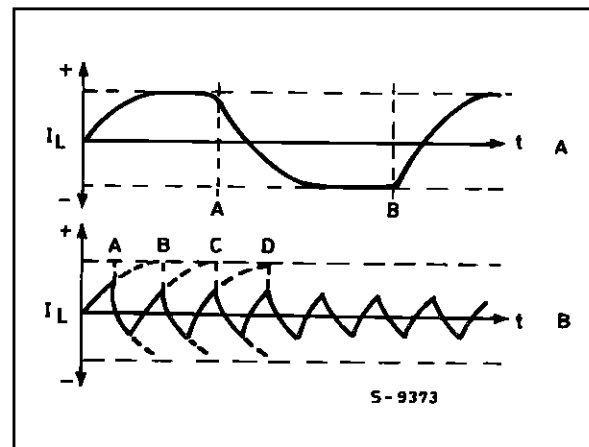
In order to keep the motor's power loss within a reasonable limit, the current in the windings must be controlled.

A simple and popular solution is to give only as much voltage as needed, utilizing the resistance ( $R_L$ ) of the winding to limit the current (fig. 4a). A more complicated but also more efficient and precise solution is the inclusion of a current generator (fig. 4b), to achieve independence from the winding resistance. The supply voltage in Fig. 4b has to be higher than the one in Fig. 4a. A comparison between both circuits in the dynamic load/working order shows visible differences.

**Figure 4 :** Resistance Current Limiter (a) and Current Generator Limiting.



**Figure 5 :** At High Step Frequencies the Winding Current cannot Reach its Setting Value because of the Continuous Direction Change.



It has already been mentioned that this power of the motor is, among others, proportional to the winding current.

In the dynamic working order a stepper motor changes poles of the winding current in the same stator winding after two steps. The speed with which the current changes its direction in the form of an exponential function depends on the specified inductance, the coil resistance and on the voltage. Fig. 5a shows that at a low step rate the winding current  $I_L$  reaches its nominal value  $V/R_L$  before the direction is changed. However, if the poles of the stator windings are changed more often, which corresponds to a high step frequency, the current no longer reaches its saturating value because of the limited change time; the power and also the torque diminish clearly at increasing number of revolutions (fig. 5).

**MORE TORQUE AT A HIGHER NUMBER OF REVOLUTIONS**

Higher torque at faster speeds are possible if a current generator as shown in Fig. 4b is used. In this application the supply voltage is chosen as high possible to increase the current's rate of change. The current generator itself limits only the phase current and becomes active only the moment in which the coil current has reached its set nominal value. Up to this value the current generator is in saturation and the supply voltage is applied directly to the winding.

Fig. 6, shows that the rate of the current increase is now much higher than in Figure 5. Consequently at higher step rates the desired current can be maintained in the winding for a longer time. The torque decrease starts only at much higher speeds.

Fig. 7 shows the relation between torque and speed in the normal graphic scheme, typical for the stepper motor. It is obvious that the power increases in the upper torque range where it is normally needed, as the load to be driven draws most energy from the motor in this range.

**EFFICIENCY - THE DECISIVE FACTOR**

The current generator combined with the high supply voltage guarantees that the rate of change of the current in the coil is sufficiently high.

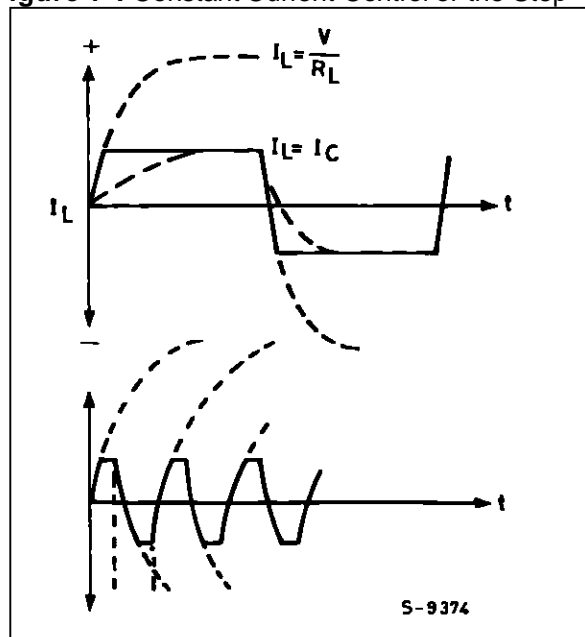
At the static condition or at low numbers of revolutions, however, this means that the power loss in the current generator dramatically increases, although the motor does not deliver any more energy in this range; the efficiency factor is extremely bad.

Help comes from a switched current regulation using the switch-transformer principle, as shown in fig. 8. The phase winding is switched to the supply

voltage until the current, detected across  $R_S$ , reaches the desired nominal value. At that moment the switch, formerly connected to  $+V_S$ , changes position and shorts out the winding. In this way the current is stored, but it decays slowly because of inner winding losses. The discharge time of the current is determined during this phase by a monostable or pulse oscillator. After this time one of the pole changing switches changes back to  $+V_S$ , starting an induction recharge and the clock-regulation-cycle starts again.

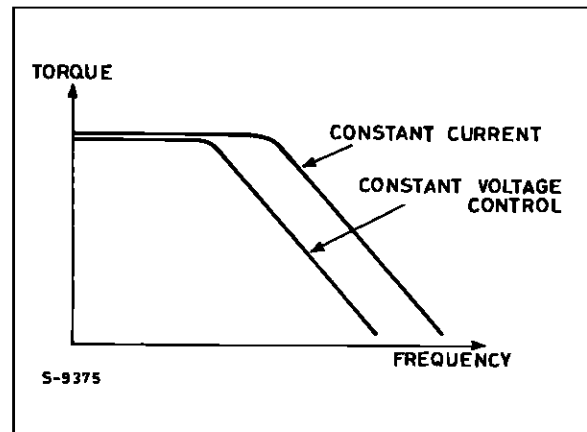
**Figure 6 :** With a Step Current Slew, it is not a Problem to Obtain, even at High Step frequencies Sufficient Current in Windings.

**Figure 7 :** Constant Current Control of the Step-



per Motor Means more Torque at High Frequency.

Since the only losses in this technique are the satu-



## APPLICATION NOTE

ration loss of the switch and that of the coil resistance, the total efficiency is very high.

The average current that flows from the power supply line is less than the winding current due to the concept of circuit inversion. In this way also the power unit is discharged. This kind of phase current control that has to be done separately for each motor phase leads to the best ratio between the supplied electrical and delivered mechanical energy.

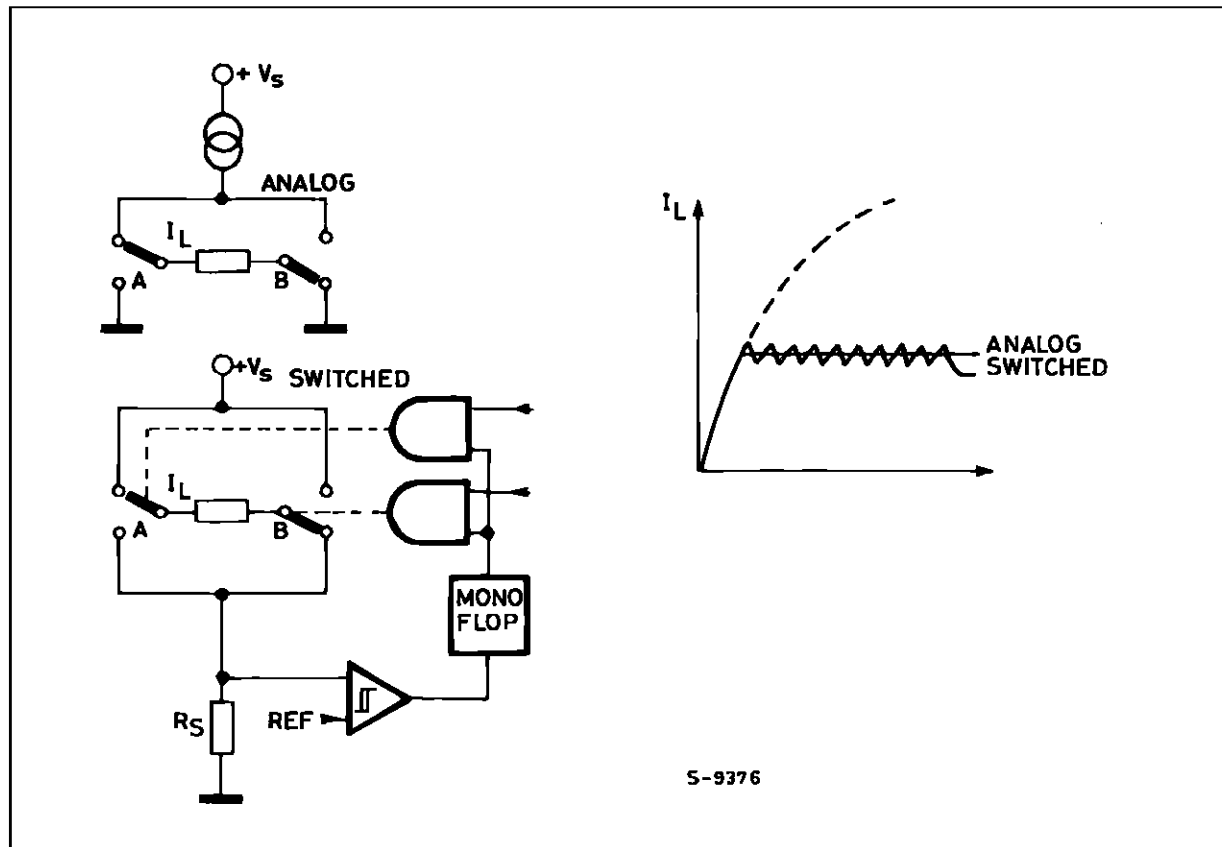
### POSSIBLE IMPROVEMENTS OF THE UNIPOLAR CIRCUIT

It would make no sense to apply the same principle to a stabilized current controlled unipolar circuit, as two more switches per phase would be necessary for the shortening out of the windings during the free phase and thus the number of components would be the same as for the bipolar circuit ; and moreover, there would be the well known torque disadvantage.

From the economic point of view a reasonable and justifiable improvement is the "Bi-Level-Drive" (fig. 9). This circuit concept works with two supply voltages ; with every new step of the motor both windings are connected for a short time to a high supply voltage. This considerably increases the current rate of change and its behaviour corresponds more or less to the stabilized power principle. After a pre-determined the switch opens, a no a lower supply voltage is connected to the winding thru a diode.

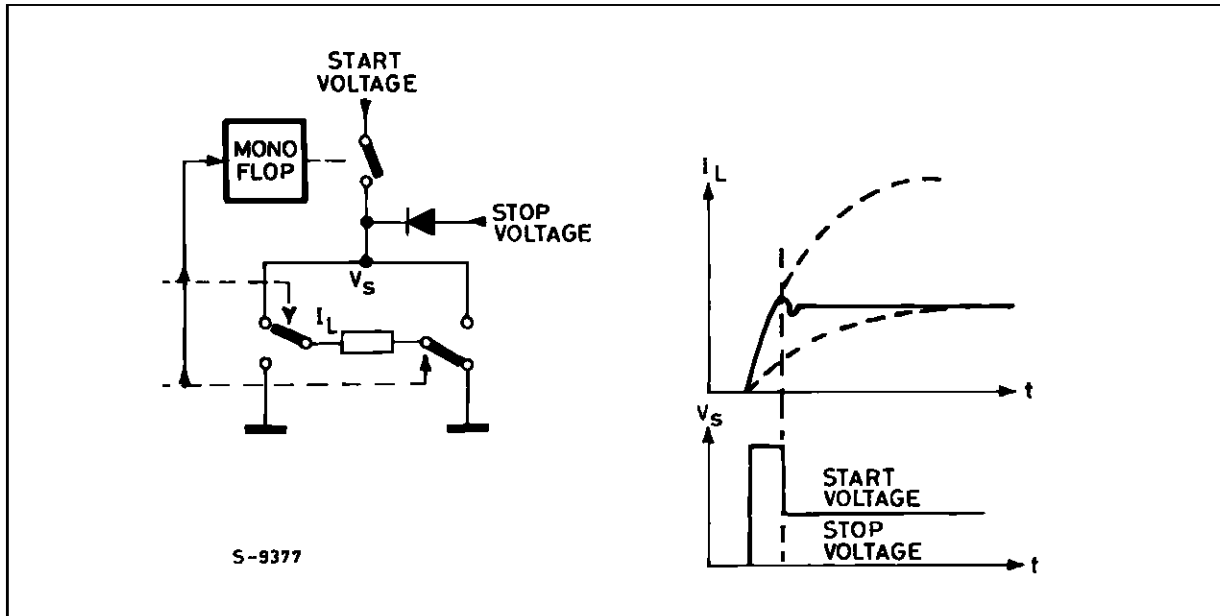
This kind of circuit by no means reaches the performance of the clocked stabilized power control as per fig. 8, as the factors : distribution voltage oscillation, B.e.m.f., thermal winding resistance, as well as the separate coil current regulation are not considered, but it is this circuit that makes the simple unipolar R/L-control suitable for many fields of application.

**Figure 8 :** With Switch Mode Current Regulation Efficiency is Increased.



S-9376

Figure 9 : At Every New Step of the Motor, it is Possible to Increase the Current Rate with a Bilevel Circuit.



**ADVANTAGES AND DISADVANTAGES OF THE HALF-STEP**

An essential advantage of a stepper motor operating at half-step conditions is its position resolution increased by the factor 2. From a 3.6 degree motor you achieve 1.8 degrees, which means 200 steps per revolution.

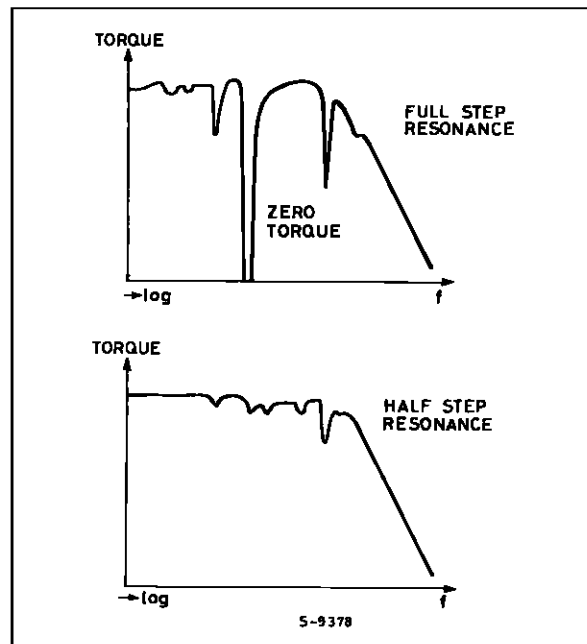
This is not always the only reason. Often you are forced to operate at half-step conditions in order to avoid that operations are disturbed by the motor resonance. These may be so strong that the motor has no more torque in certain step frequency ranges and loses completely its position (fig. 10). This is due to the fact that the rotor of the motor, and the changing magnetic field of the stator forms a spring-mass-system that may be stimulated to vibrate. In practice, the load might deaden this system, but only if there is sufficient frictional force.

In most cases half-step operation helps, as the course covered by the rotor is only half as long and the system is less stimulated.

The fact that the half-step operation is not the dominating or general solution, depends on certain disadvantages:

- the half-step system needs twice as many clock-pulses as the full-step system ; the clock-frequency is twice as high as with the full-step.
- in the half-step position the motor has only about half of the torque of the full-step.

Figure 10 :The Motor has no More Torque in Certain Step Frequency Ranges with Full Step Driving.



For this reason many systems use the half-step operation only if the clock-frequency of the motor is within the resonance risk area.

The dynamic loss is higher the nearer the load moment comes to the limit torque of the motor. This effect decreases at higher numbers of revolutions.

## APPLICATION NOTE

### TORQUE LOSS COMPENSATION IN THE HALF-STEP OPERATION

It's clear that, especially in limit situations, the torque loss in half-step is a disadvantage. If one has to choose the next larger motor or one with a double resolution operating in full-step because of some insufficient torque percentages, it will greatly influence the costs of the whole system.

In this case, there is an alternative solution that does not increase the costs for the bipolar chopping stabilized current drive circuit.

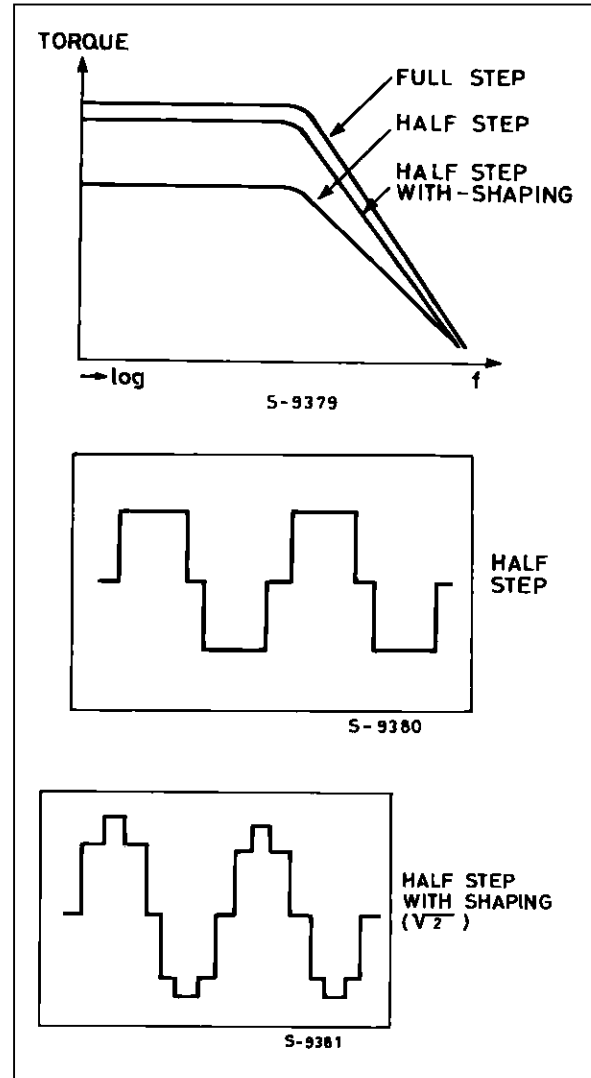
The torque loss in the half-step position may be compensated for by increasing the winding current by the factor  $\sqrt{2}$  in the phase winding that remains active. This is also permissible if, according to the motor data sheet, the current limit has been reached, because this limit refers always to the contemporary supply with current in both windings in the full-step position. The factor  $\sqrt{2}$  increase in current doubles the stray power of the active phase. The total dissipated power is like that of the full-step because the non-active phase does not dissipate power.

The resulting torque in the half-step position amounts to about 90 % of that of the full-step, that means dynamically more than 95 % torque compared to the pure full-step ; a neglectable factor.

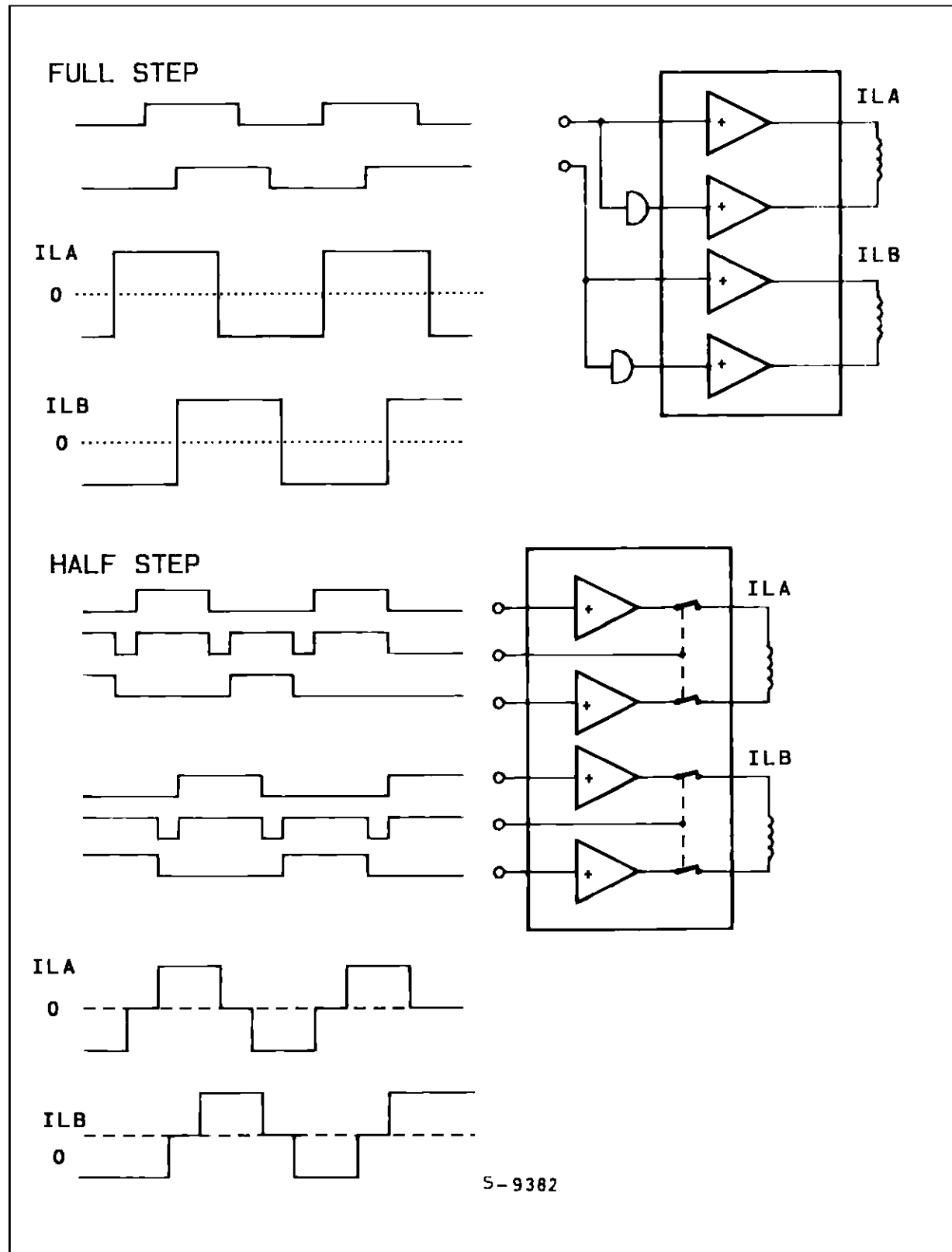
The only thing to avoid is stopping the motor at limit current conditions in a half-step position because it would be like a winding thermal phase overload concentrated in one.

The best switch-technique for the half-step phase current increase will be explained in detail later on Fig. 11 shows the phase current of a stepping motor in half-step control with an without phase current increase and the pertinent curves of step frequency and torque.

Figure 11 : Half Step Driving with Shaping Allows to Increase the Motor's Torque to about 95 % of that of the Full Step.



**Figure 12** : Only Two Signals for Full Step Driving are Necessary while Four (six if three-state is needed on the output stages) for half Step.



## APPLICATION NOTE

### DRIVE SIGNALS FOR THE MICRO ELECTRONIC

A direct current motor runs by itself if you supply it with voltage, whereas the stepping motor needs the commutation signal in form of several separated but linkable commands. In 95 % of the applications today, the origin of these digital commands is a micro-processor system.

In its simplest form, a full-step control needs only two rectangular signals in quadrature. According to which phase is leading, the motor axis rotates clockwise or counter-clockwise, whereby the rotation speed is proportional to the clock frequency.

In the half-step system the situation becomes more complicated. The minimal two control signals become four control signals. In some conditions as many as six signals are needed. If the Tri-state-command for the phase ranges without current, necessary for high motor speeds, may not be obtained from the 4 control signals. Fig. 12 shows the relationship between the phase current diagram and the control signal for full and half-step.

Since all signals in each mode are in defined relations with each other, it is possible to generate them using standard logic. However, if the possibility to

choose full and half-step is desired, a good logic implementation becomes quite expensive and an application specific integrated circuit would be better. Such an application specific integrated circuit could reduce the number of outputs required from a micro-processor from the 6 required to 3 static and dynamic control lines.

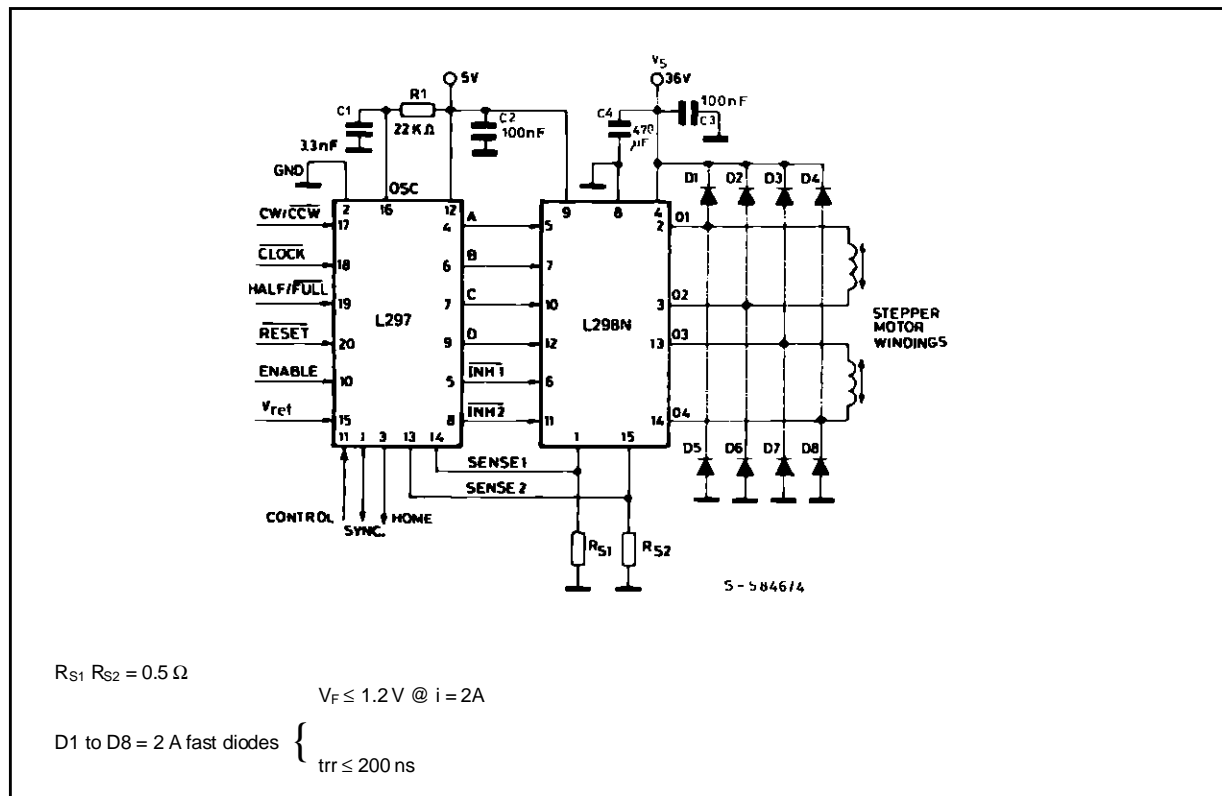
A typical control circuit that meets all these requirements is the L297 unit (fig. 13).

Four signals control the motor in all operations :

1. CLOCK : The clock signal, giving the stepping command
2. RESET : Puts the final level signals in a defined start position
3. DIRECTION : Determines the sense of rotation of the motor axis.
4. HALF/FULL : Decides whether to operate in full or in half-step.

Another inhibit input allows the device to switch the motor output into the Tri-state-mode in order to prevent undesired movements during undefined operating conditions, such as those that could occur during.

**Figure 13 :** The L297 avoids the Use of Complicated Standard Logic to Generate Both Full and Half-step Driving Signals Together with Chopper Current Control.





## SWITCH-MODE CURRENT REGULATION

The primary function of the current regulation circuit is to supply enough current to the phase windings of the motor, even at high step rates.

The functional blocks required for a switchmode current control are the same blocks required in switching power supplies ; flip-flops, comparators ; and an oscillator are required. These blocks can easily be included in the same IC that generates the phase control signals. Let us consider the implementation of chopper current control in the L297.

The oscillator on pin 16 of the L297 resets the two flip-flops at the start of each oscillator period. The flip-flop outputs are then combined with the outputs of the translator circuit to form the 6 control signals supplied to the power bridge (L298).

When activated, by the oscillator, the current in the winding will raise, following the L/R time constant curve, until the voltage across the sense resistor (pin 1, 15 of L298) is equal to the reference voltage input (pin 15, L297) the comparator then sets the flip-flop, causing the output of the L297 to change to an equi-phase condition, thus effectively putting a short circuit across the phase winding. The bridge is activated into a diagonally conductive state when the oscillator resets the flip-flop at the start of the next cycle.

Using a common oscillator to control both current regulators maintains the same chopping frequency for both, thus avoiding interference between the two.

The functional block diagram of the L297 and the power stage (L298) are shown in Figure 14 along with the operating wave forms.

An important characteristics of this circuit implementation is that, during the reset time, the flip-flops are kept reset. The reset time can be selected by selecting the impedance of the R/C network or pin 16. In this way, the current spike and noise across the sen-

se resistors that may occur during switching will not cause a premature setting of the flip-flop. Thus the recovery current spike of the protection diodes can be ignored and a filter in the sense line is avoided.

## THE RIGHT PHASE CURRENT FOR EVERY OPERATING CONDITION

The Chopper principle of the controller unit reveals that the phase current in the motor windings is controlled by two data : the reference voltage at pin 15 of the controller and the value of the sense resistance at pins 1 and 15 of the L298, that is  $I_L = V_{REF}/R_S$ . By changing  $V_{REF}$  it is very easy to vary the current within large limits. The only question is for which purpose and at which conditions.

More phase current means more motor torque, but also higher energy consumption.

An analysis of the torque consumption for different periods and load position changes shows that there is no need for different energies.

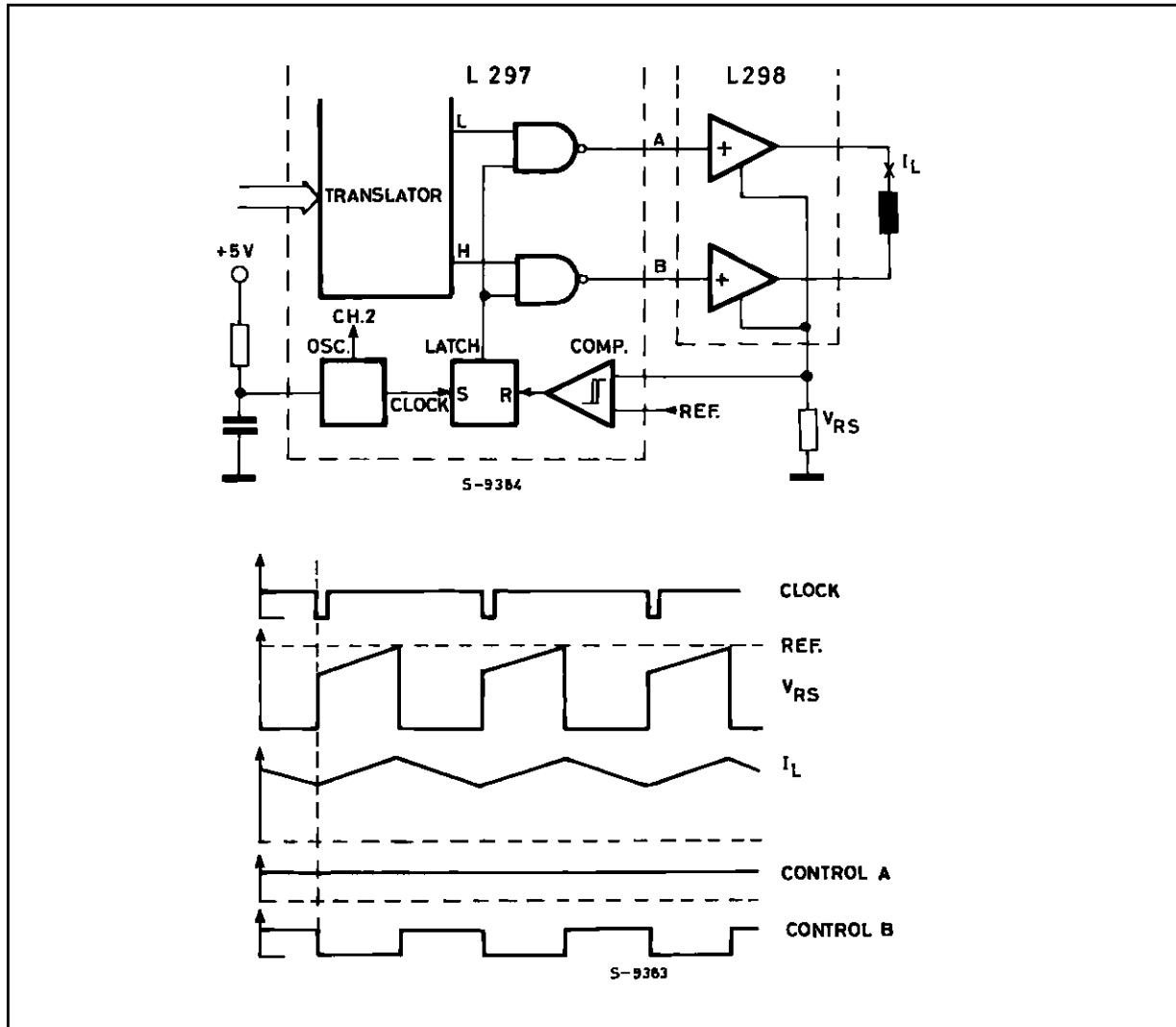
There is a high energy need during the acceleration or break phases, whereas during continuous operation or neutral or stop position less energy has to be supplied. A motor with its phase current continuously oriented at the load moment limit, even with the load moment lacking, consumes needlessly energy, that is completely transformed into heat.

Therefore it is useful to resolve the phase current in at least two levels controllable from the processor. Fig. 18 shows a minimal configuration with two resistance and one small signal transistor as change-over switch for the reference input. With another resistance and transistor it is possible to resolve 2 Bits and consequently 4 levels. That is sufficient for all imaginable causes.

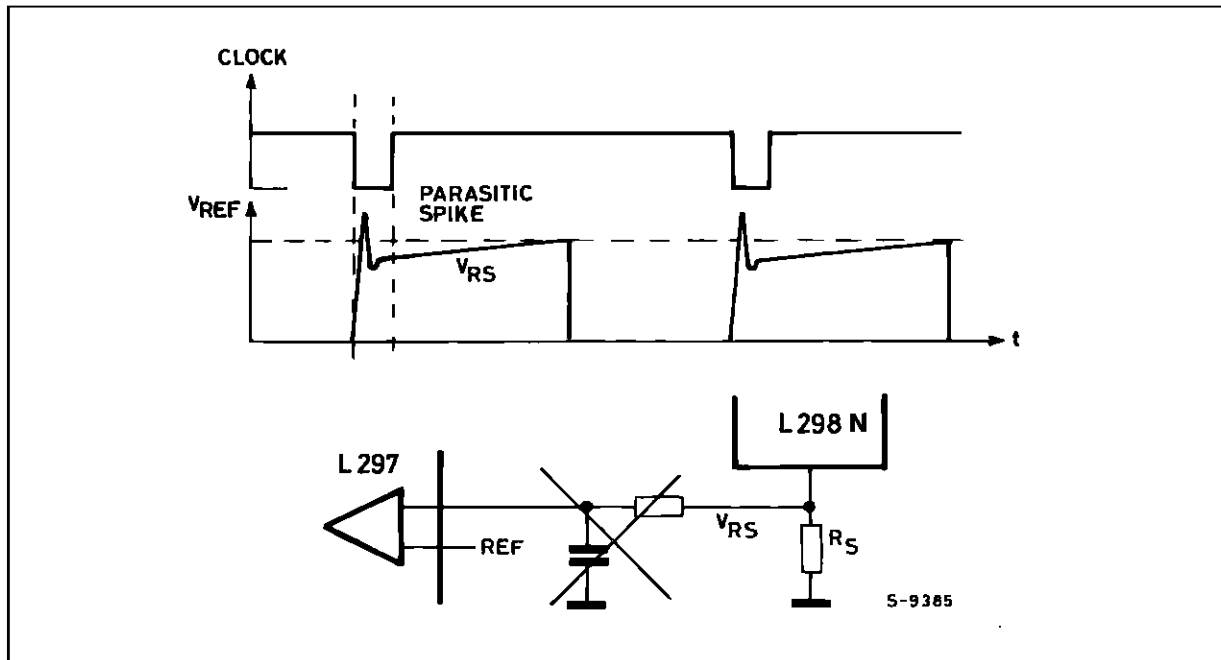
Fig. 16 shows a optimal phase current diagram during a positioning operation.

## APPLICATION NOTE

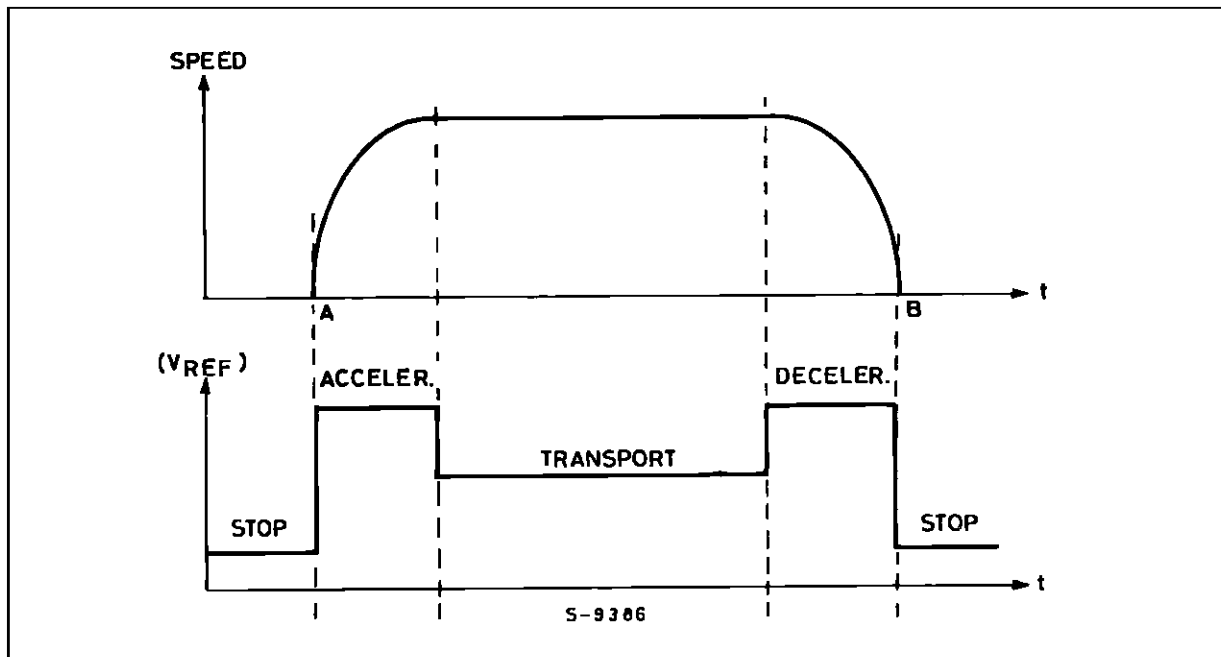
**Figure 14 :** Two ICs and very Few External Components Provide Complete Microprocessor to Bipolar Step-per Motor Interface.



**Figure 15 :** Because of the Set-dominant Latch Inside the L297 it is Possible to Hide Current Spikes and Noise Across the Sense Resistors thus Avoiding External Filters.



**Figure 16 :** More Energy is needed During The Acceleration and break Phases Compared the Continuous Operation, Neutral or Stop Position.



## APPLICATION NOTE

### HIGH MOTOR CLOCK RESETS IN THE HALF-STEP SYSTEM

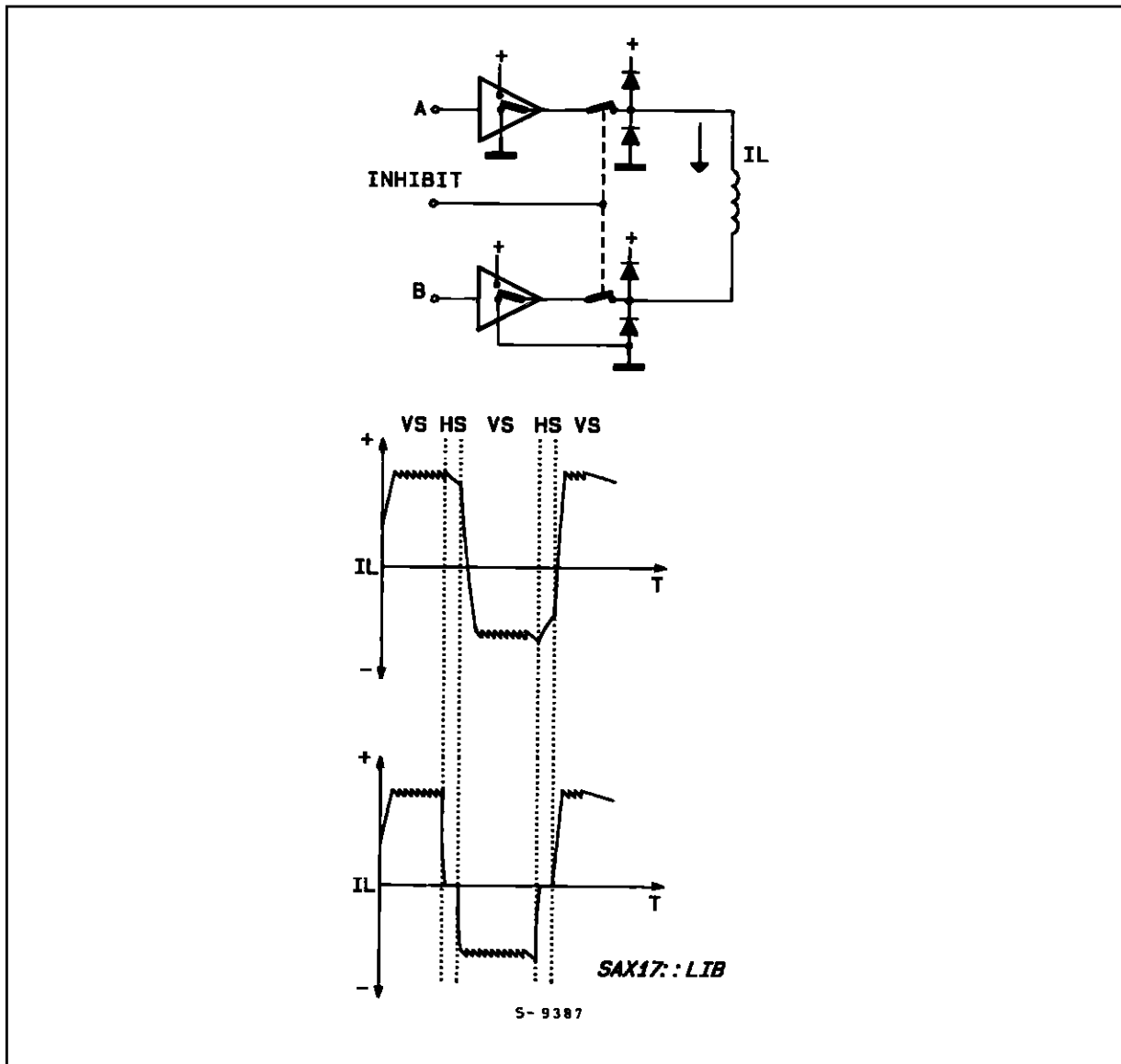
In the half-step position one of the motor phases has to be without current. If the motor moves from a full-step position into a half-step position, this means that one motor winding has to be completely discharged. From the logic diagram this means for the high level bridge an equivalent status of the input signals A/B, for example in the HIGH-status. For the coil this means short circuit (fig. 17 up) and consequently a low reduction of the current. In case of high half-step speeds the short circuit discharge time constant of the phase winding is not sufficient to discharge the current during the short half-step pha-

ses. The current diagram is not neat, the half step is not carried out correctly (fig. 17 center).

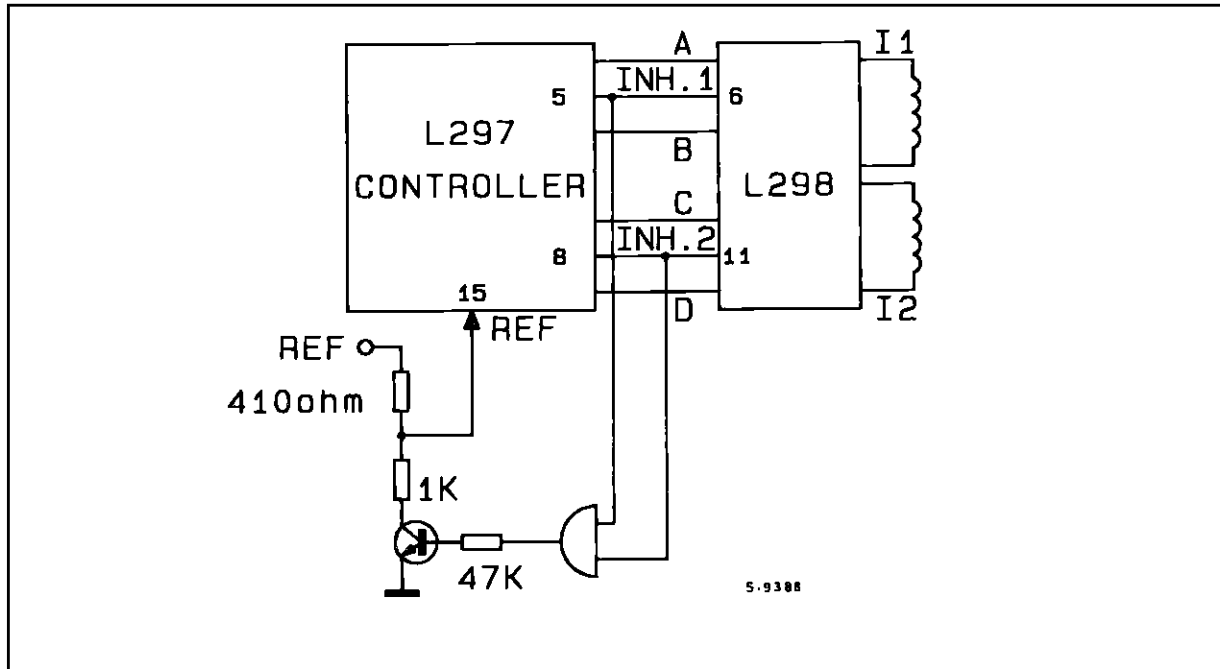
For this reason the L297 controller-unit generates an inhibit-command for each phase bridge, that switches the specific bridge output in the half-step position into Tri-state. In this way the coil can start swinging freely over the external recovery diodes and discharge quickly. The current decrease rate of change corresponds more or less to the increase rate of change (fig. 17 below).

In case of full-step operation both inhibit-outputs of the controller (pin 5 and 8) remain in the HIGH-status.

**Figure 17** : The Inhibit Signal Turns Off Immediately the Output Stages Allowing thus a Faster Current Decay (mandatory with half-step operation).



**Figure 18** : With This Configuration it is Possible to Obtain Half-step with Shaping Operation and Therefore More Torque.



### MORE TORQUE IN THE HALF-STEP POSITION

A topic that has already been discussed in detail. So we will limit our considerations on how it is carried out, in fact quite simply because of the reference voltage controlled phase current regulation.

With the help of the inhibit-signals at outputs 5 and 8 of the controller, which are alternatively active only when the half-step control is programmed, the reference voltage is increased by the factor 1.41 with a very simple additional wiring (fig. 18), as soon as one of the two inhibit-signals switches LOW. This increases the current in the active motorphase proportionally to the reference voltage and compensates the torque loss in this position. Fig. 19 shows clearly that the diagram of the phase current is almost sinusoidal, in principle the ideal form of the current graph.

To sum up we may say that this half-step version offers most advantages. The motor works with poor resonance and a double position resolution at a torque, that is almost the same as that of the full-step.

### BETTER GLIDING THAN STEPPING

If a stepper motor is supposed to work almost gliding and not step by step, the form of the phase current diagram has to be sinusoidal.

The advantages are very important :

- no more phenomena of resonance
- drastic noise reduction
- connected gearings and loads are treated with care
- the position resolution may be increased further.

However, the use of the L297 controller-unit described until now is no longer possible of the more sophisticated form of the phase current diagram the Controller may become simpler in its functions.

Fig. 20 shows us an example with the L6505 unit. This IC contains nothing more than the clocked phase current regulation which works according to the same principle as L297. The four control signals emitting continuously a full-step program are now generated directly by the microprocessor. In order to obtain a sinusoidal phase current course the reference voltage inputs of the Controller are modulated with sinusoidal half-waves.

The microprocessor that controls the direction of the current phase with the control signals also generates the two analog signals.

For many applications a microprocessor with dedicated digital to analog converters can be chosen. Eliminating the need for separate D/A circuits.

About 5 bit have proved to be the most suitable sud-

## APPLICATION NOTE

division of the current within one full-step. A higher resolution brings no measurable advantages. On the contrary, the converter clock frequency is already very high in case of low motor revolutions and very difficult to process by the processor-software. It is recommended to reduce the D/A resolution at high step frequencies.

In case of higher motor revolutions it is more convenient to operate only in full-step, since harmonic control is no longer an advantage as the current has only a triangular waveform in the motor winding.

### PRECISION OF THE MICRO STEP

Any desired increase of the position resolution between the full step position has its physical limits. Those who think it is possible to resolve a  $7.2^\circ$  -

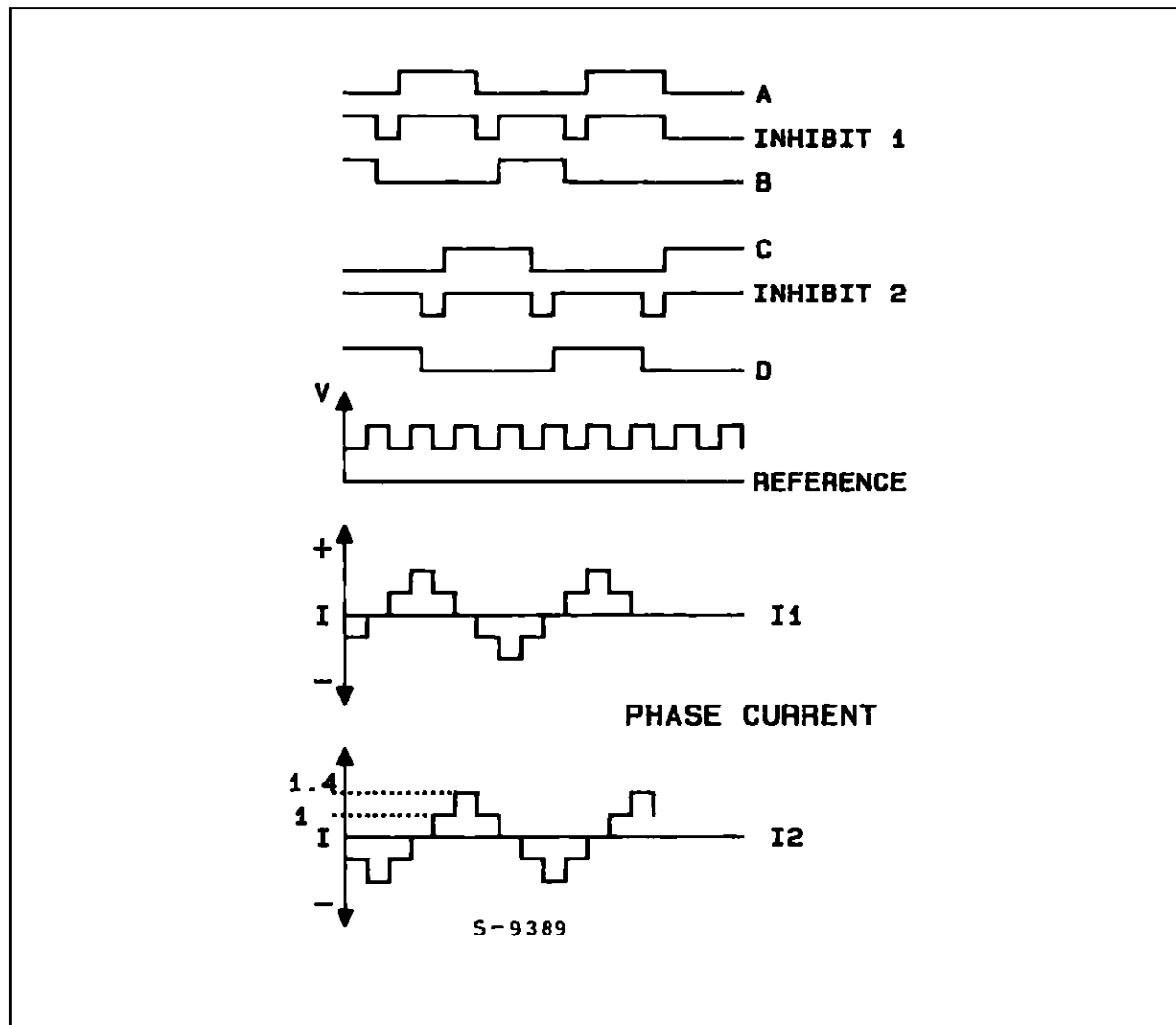
stepper motor to  $1.8^\circ$  with the same precision as a  $1.8^\circ$  - motor in full-step will be received, as there are several limits :

The rise rate of the torque diagram corresponding to the twisting angle of the rotor for the  $7.2^\circ$  - motor is flatter by a factor of 4 then for the original  $1.8^\circ$  - motor. Consequently with friction or load moment, the position error is larger (fig. 21).

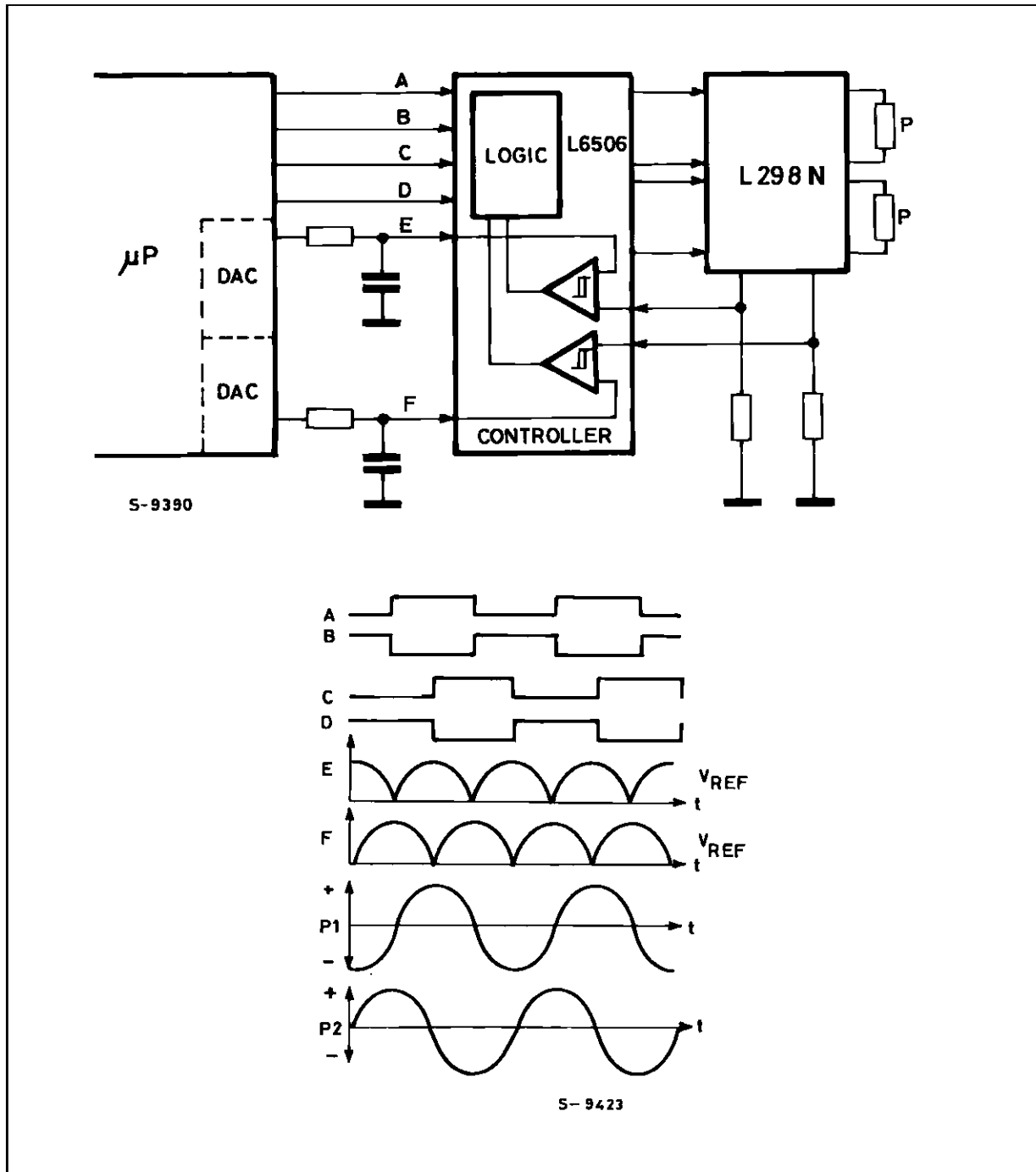
For most of the commercial motors there isn't a sufficiently precise, linear relationship between a sinusoidal-current-diagram and an exact micro step angle. The reason is a dishomogeneous magnetic field between the rotor and the two stator fields.

Above all, problems have to be expected with motors with high pole feeling. However, there are special stepper motors in which an optimized micro step operation has already been considered during the construction phase.

**Figure 19** : The Half-step with Shaping Positioning is Achieved by Simply Changing Reference Voltages.

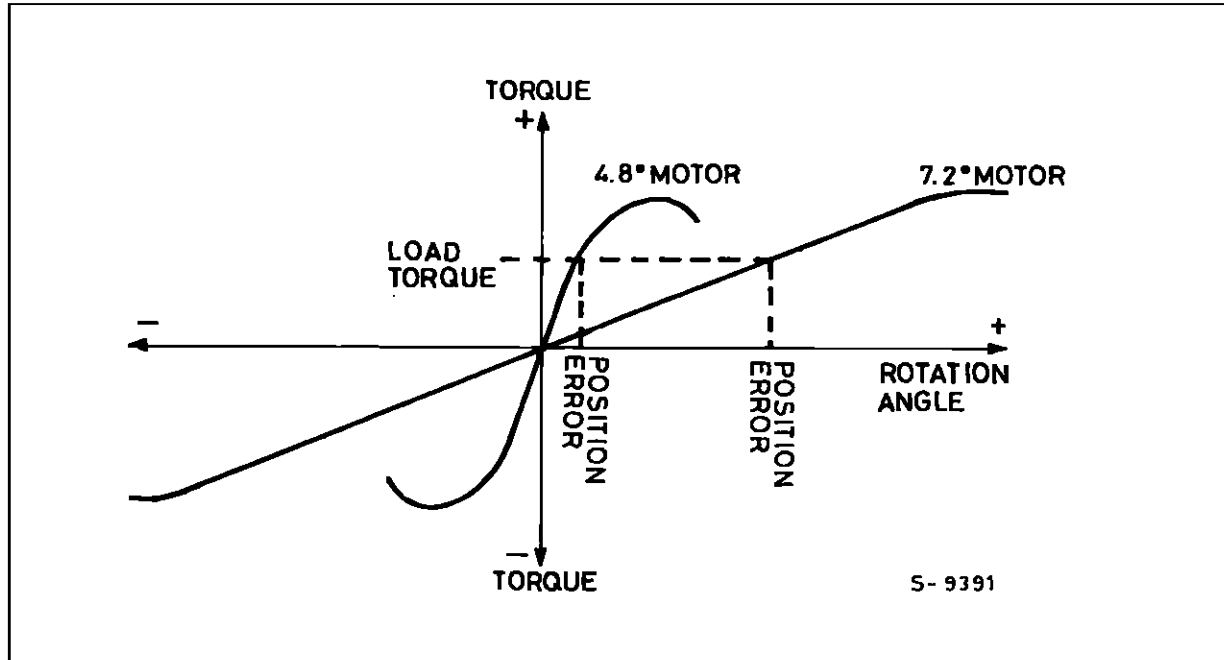


**Figure 20** : L6506 Unit Gives The Possibility to Modulate Separately the Two Reference Voltage Inputs in Order to obtain a Sinusoidal Phase Current.



## APPLICATION NOTE

**Figure 21** : Better Resolution is achieved with Low Degree Motor but More torque is delivered with high Degree Motor.



### CONCLUSIONS

The above described application examples of modern integrated circuits show that output and efficiency of stepper motors may be remarkably increased without any excessive expense increase like before.

Working in limit areas, where improved electronics with optimized drive sequences allow the use of less expensive motors, it is even possible to obtain a cost reduction.



Information furnished is believed to be accurate and reliable. However, SGS-THOMSON Microelectronics assumes no responsibility for the consequences of use of such information nor for any infringement of patents or other rights of third parties which may result from its use. No license is granted by implication or otherwise under any patent or patent rights of SGS-THOMSON Microelectronics. Specifications mentioned in this publication are subject to change without notice. This publication supersedes and replaces all information previously supplied. SGS-THOMSON Microelectronics products are not authorized for use as critical components in life support devices or systems without express written approval of SGS-THOMSON Microelectronics.

© 1995 SGS-THOMSON Microelectronics - All Rights Reserved

SGS-THOMSON Microelectronics GROUP OF COMPANIES

Australia - Brazil - France - Germany - Hong Kong - Italy - Japan - Korea - Malaysia - Malta - Morocco - The Netherlands - Singapore - Spain - Sweden - Switzerland - Taiwan - Thailand - United Kingdom - U.S.A.